

ASSEMBLY INSTRUCTIONS & PARTS MANUAL

Jumbo Wardrobe Cabinet Unassembled Model J2478A-N-W



RETAIN INSTRUCTIONS FOR FUTURE REFERENCE



LOAD CAPACITIES PER SHELF LEVEL EVENLY DISTRIBUTED	
UNIT SIZE	WEIGHT CAPACITY
48w x 24d	400 lbs.

GENERAL SAFETY INFORMATION

Some parts may have sharp edges. CARE must be taken when handling various pieces to avoid injury. For safety, wear a pair of work gloves when assembling or performing any maintenance on the units.

LIMITED WARRANTY

Tennsco warrants goods purchased hereunder to be free of defects in materials and workmanship for a period of one (1) year from the date of shipment, hereunder. This warranty shall not apply in the event goods are damaged as a result of misuse, abuse, neglect, accident, improper application, modification or repair by persons not authorized by Seller, where goods are damaged during shipment, or where the date stamps on the goods have been defaced, modified or removed. UNLESS CONSIDERED UNENFORCEABLE OR UNLAWFUL UNDER APPLICABLE LAW:

- a. ALL IMPLIED WARRANTIES, INCLUDING BUT NOT LIMITED TO WARRANTIES OR MERCHANTABILITY AND FITNESS FOR A PARTICULAR PURPOSE ARE HEREBY EXCLUDED:
- b. BUYERS REMEDY, IF ANY, FOR ANY DEFECTIVE GOODS SHALL BE LIMITED TO A REFUND BY SELLER OR REPLACEMENT OF THE GOODS AT SELLER'S OPTION, AND SHALL IN NO EVENT INCLUDE DAMAGES OF ANY KIND, WHETHER INCIDENTAL, CONSEQUENTIAL OR OTHERWISE.

NO GOODS ACCEPTED FOR RETURN WITHOUT PRIOR APPROVAL. Seller shall have the right to inspect any goods claimed to be defective at Buyers place of business or require Buyer to return the goods to Seller for inspection on Seller's premises. Transportation charges covering returned goods will be borne by Seller only if such goods are proven to be defective, are covered by this warranty and are returned within the warranty period stated above.



PROUDLY MADE IN THE U.S.A.

Tennsco LLC, Dickson, TN 37056-1888 • (866) 446-8686

ASSEMBLY OF J2478A-N-W CABINET

Tools Needed: A free 1¹/₃₂" nut driver is included with each Tennsco cabinet.
Two people are recommended for assembly. Approximate assembly time: 30-40 minutes.

1. The reference numbers used throughout this sheet refer to the illustration on the back cover. This is to help you to identify the various parts as they are mentioned.

2. Place the 2-piece cabinet back (Ref. No. 1) on a protected surface to prevent scratching the paint. The flange on the bottom of the back should be facing upward. Bolt the back panels together with seven bolts and nuts (Ref. Nos. 19 & 20).

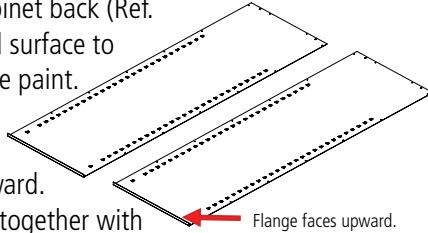

NOTE: When bolting the unit together, leave the bolts slightly loose until Step 10, unless otherwise specified.

3. Attach the left side (Ref. No. 2) to the back by placing flange (A) around the back and bolting together with seven bolts and nuts. Be sure that the lances on all shelf adjustment strips (B) point in the same direction.

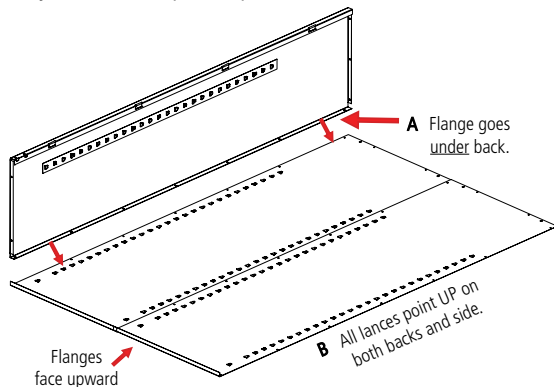

4. Attach the top (Ref. No. 5) to the unit by sliding the outer flange over the back of the unit and the side flange on the top over the side panel. The threaded studs should go through the holes in the top flange of the side and fasten with three nuts. Attach the back to the top using four bolts and nuts.

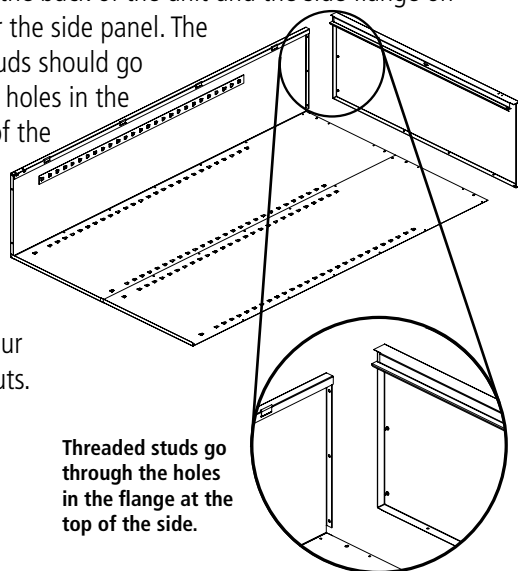

5. Attach the right side (Ref. No. 3) to the back in the same manner as you did in step 3, again, making sure that the flange is around the back and that the lances on the shelf adjustment strips are pointed in the same direction as those on the back and left side. Push the side panel up so the studs in the top go through the holes in the top flange of the side and fasten with three nuts as in step 4).

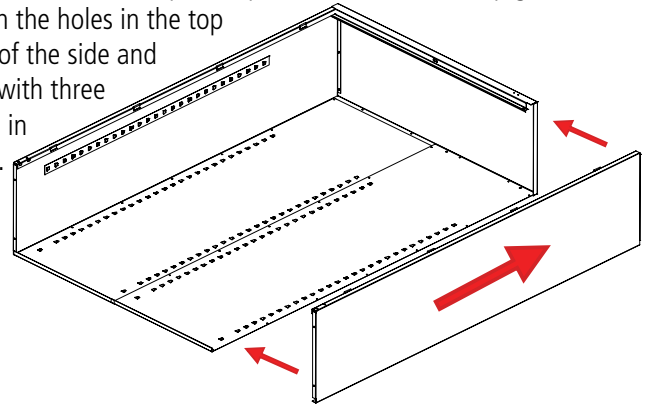

6. Attach the sill (Ref. No. 8) to the sides. Place nuts loosely on each of the studs and slide the ends of the sill into the slots on both sides of the unit. Then, securely tighten the nuts.

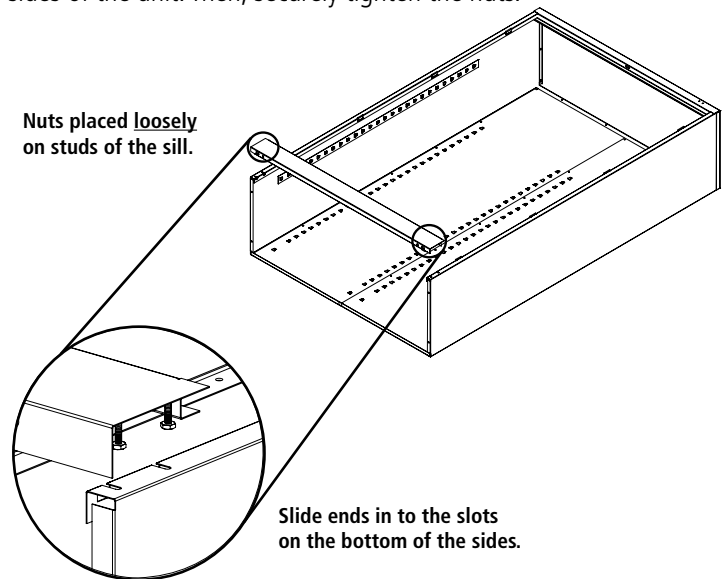

7. Place the rear flange of one of the shelves (Ref. No. 4) into the four bottom lances of the back. The front of the shelf will rest on the sill.

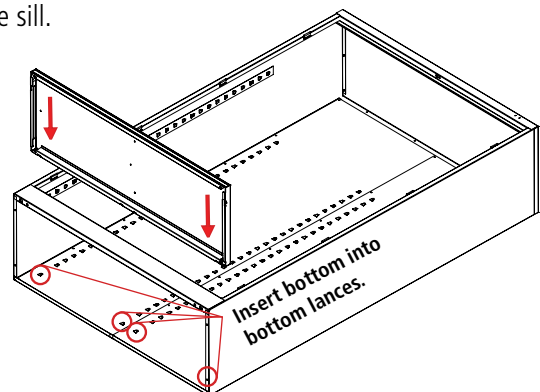

- 8.** Insert the second shelf into the second lance from the top of the sides and back.

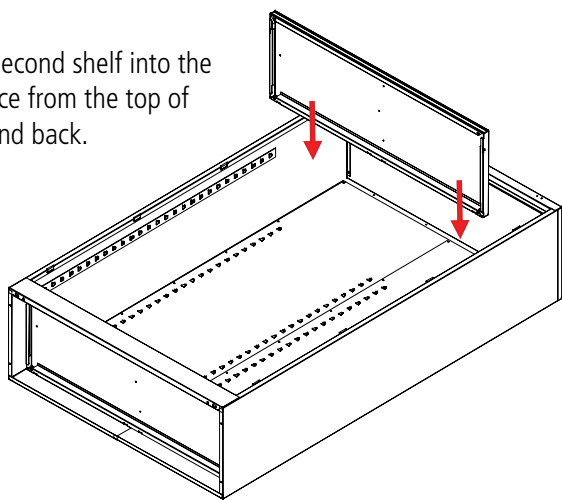

- 9.** Using two people, set the unit upright. Attach the left door (Ref. No. 6) and right door (Ref. No. 7) to the unit by placing the door on the hinges, aligning the hinges on the door to the hinges on the sides, pushing the hinge pins (Ref. No. 17) through both hinges. Tap the top of each hinge pin until it is fully seated.

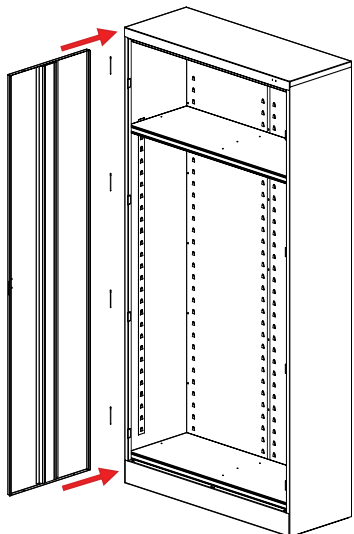

- 10.** Attach the left coat rod bracket (Ref. No. 9) to the underside of the shelf, inserting one bolt and nut through the hole provided on the far right and far left side. The open side of the side brackets should face into the unit. Place the last bracket on the coat rod (Ref. No. 10) and insert the rod into the other by flexing the second bracket. Secure the bracket to the middle of the shelf with one bolt and nut through the hole provided in the center of the shelf. At this time, tighten all of the nuts and bolts around the entire unit.

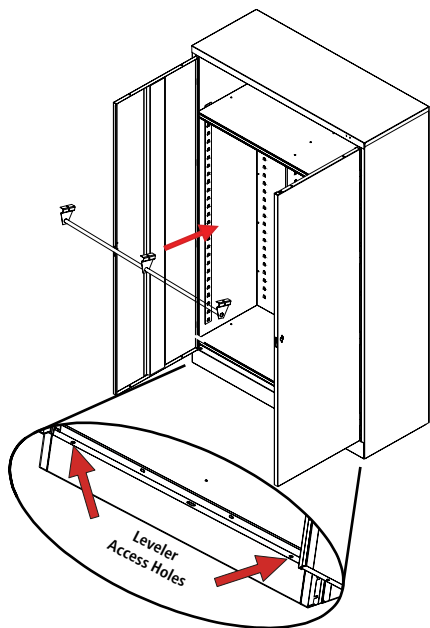

- 11.** The cabinet must be level in order for the doors to close properly. Levelers may be adjusted by placing the nut driver through the hole in each end of the sill and adjusting the leveling screw.

Handle/Locking System Installation

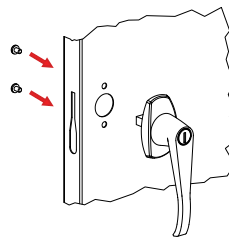

- 1.** Place the locking handle (Ref. No. 12) on the right hand door and fasten with two #8-32 X 1/4 hex-head bolts and lock washers, provided with the handle.

- 2.** Turn the handle to the open position and place the locking cam (Ref. No. 13) over the square shank of the door handle. The latch must be facing downward as shown. Then place the locking cotter pin (Ref. No. 15) through the hole of the square shank.

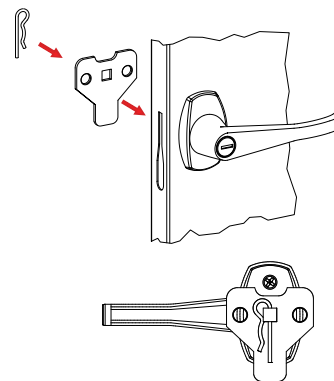

- 3.** With the handle still in the open position, hook the locking bars (Ref. No. 11) to the locking cam (see "A" at left). Once in position, slowly rotate the door handle to the closed position so the lock bars protrude from the holes at the top and bottom of the door (shown at right, below).

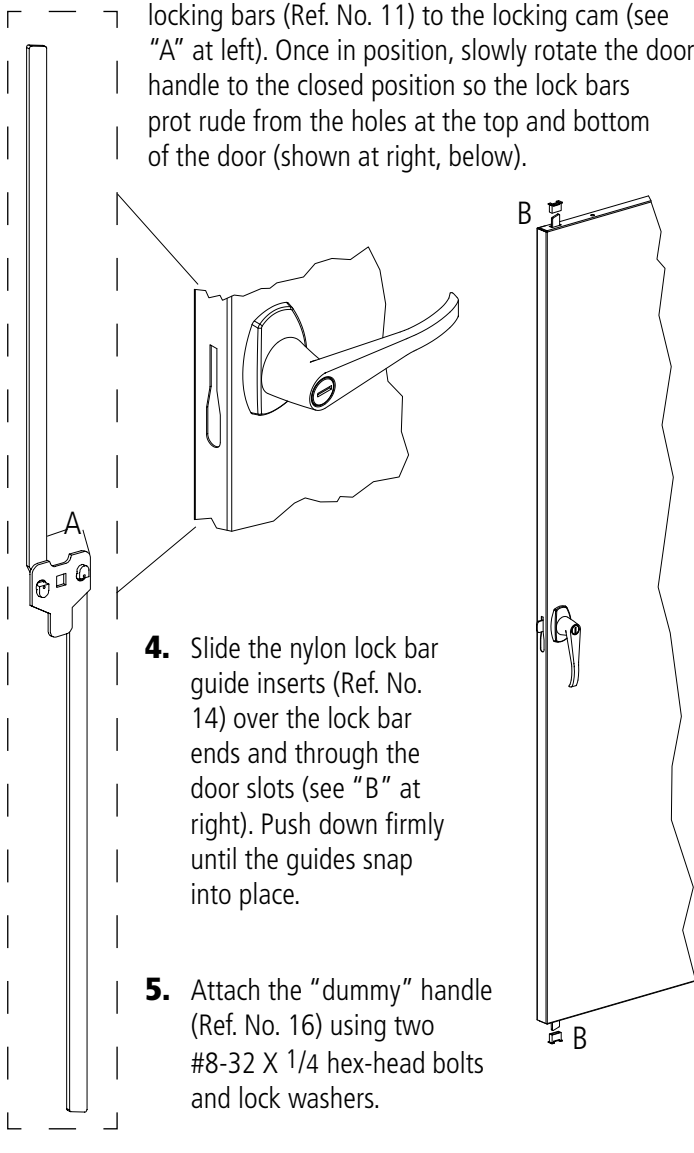

- 4.** Slide the nylon lock bar guide inserts (Ref. No. 14) over the lock bar ends and through the door slots (see "B" at right). Push down firmly until the guides snap into place.

- 5.** Attach the "dummy" handle (Ref. No. 16) using two #8-32 X 1/4 hex-head bolts and lock washers.

REPLACEMENT PARTS

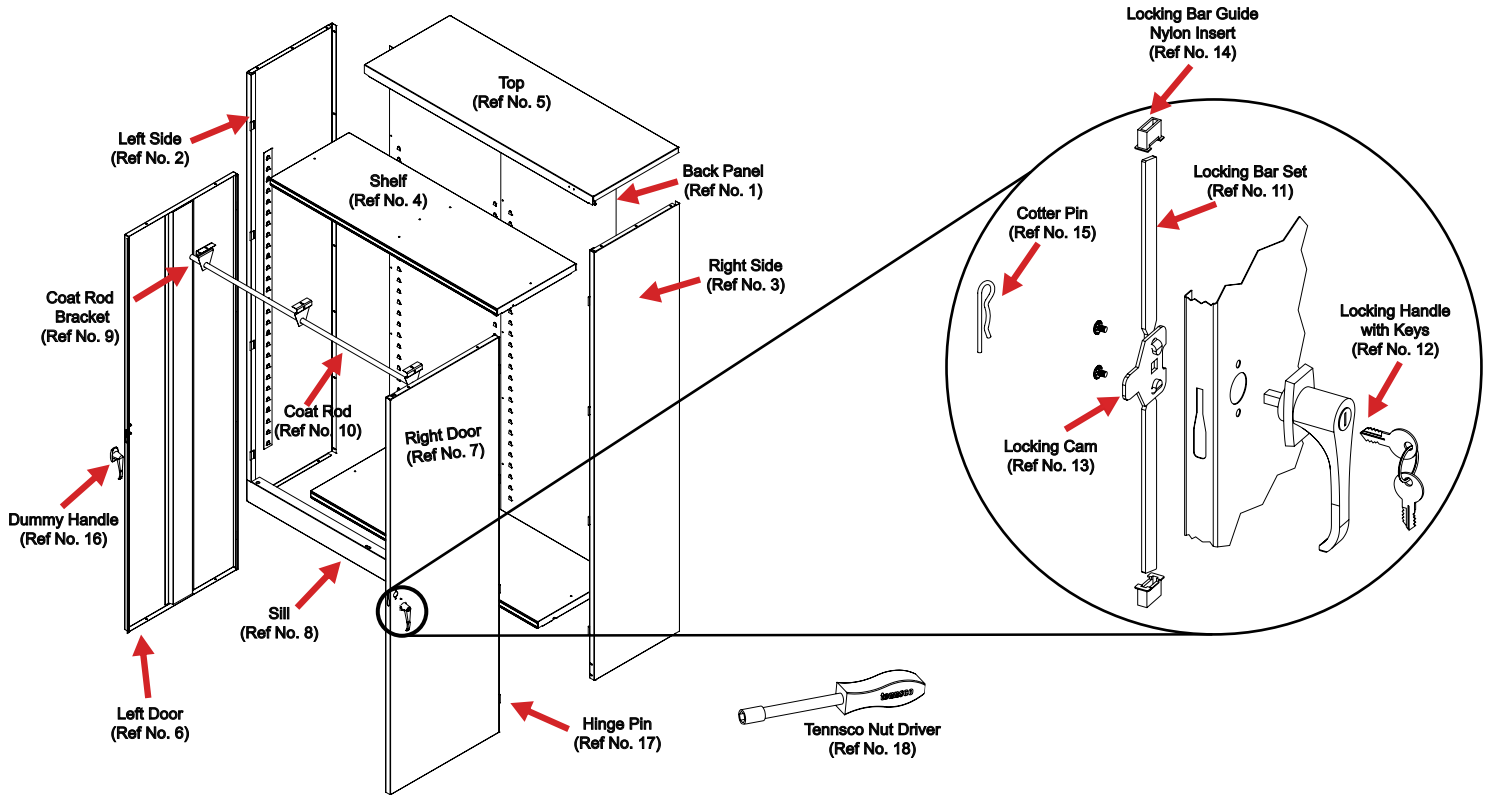

REF. NO.	DESCRIPTION	QTY.	PART NO.
1	Back Panels	2	055BA
2	Left Side	1	056LS
3	Right Side	1	056RS
4	Shelf	2	307
5	Top	1	055T24
6	Left Door	1	056LD
7	Right Door	1	056RD
8	Sill	1	055SI
9	Coat Rod Bracket	3	045RB
10	Coat Rod	1	055CR
11	Locking Bar Set	1	043LB
12	Locking Handle w/keys & hardware	1	043LH
13	Locking Cam*	1	944LC
14	Locking Bar Guide Insert (Nylon)*	2	944GI
15	Cotter Pin*	1	CTPRN
16	Dummy Handle*	1	043DH
17	Hinge Pins*	8	944HP
18	Tensco Nut Driver	1	TOOL-2
19	#8-32 x 3/8" bolts (not shown above)	25	**
20	#8-32 nuts (not shown above)	35	**

*Included in Ref. No. 12, locking handle with keys and hardware (Part No. 043LH).

** Available Locally

NOTE: Additional hardware may be included for replacement purposes.

Tensco makes every effort to ensure that all units ship complete with all parts and arrive undamaged. However, should your unit contain missing or damaged parts, please contact your purchase location.